



MASON INDUSTRIES, Inc.

Manufacturers of Vibration Control Products

350 Rabro Drive
Hauppauge, NY 11788
631/348-0282
FAX 631/348-0279
Info@Mason-Ind.com
www.Mason-Ind.com

2101 W. Crescent Ave., Suite D
Anaheim, CA 92801
714/535-2727
FAX 714/535-5738
Info@MasonAnaheim.com
www.MasonAnaheim.com

FREE STANDING SPRING MOUNTS and HEIGHT SAVING BRACKETS

TYPE SLF

SLF-200-6 BULLETIN

The Type **SLF** spring design evolved after many years of experience using springs within guided housing as the primary isolator. Since the old housing acted telescopically, the internal springs were designed for vertical stiffness and deflection only. Early attempts to use these tall slender springs out of their housing failed as the springs showed immediate instability or they fell over when subjected to minor horizontal forces.

It was important to eliminate the housing as they had a tendency to bind whenever they were cocked and to transmit vibration in the horizontal directions. We knew that if the springs were unhampered they would not only do better vertically, but do an equally fine job in isolating the horizontal disturbances.

Our research showed that springs could be designed with horizontal stiffnesses as high, or even higher than the vertical by carefully adhering to the ratios of the spring's compressed height to the mean coil diameter, and the static deflection to the compressed height as shown in the graph.



**SINGLE SPRING
1" (25mm) Deflection
SLF MOUNT**

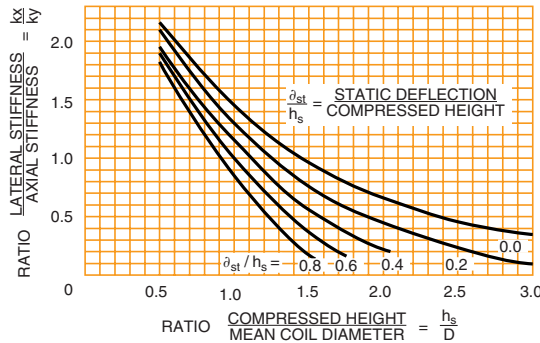

Starting with the 1" (25mm) deflection series, we paid great attention to these design factors and our springs became short stable columns. When we had tested and were completely satisfied with the 1" (25mm) designs, we moved on the 2" (51mm), 3" (76mm), 4" (102mm) and 5" (127mm) deflection series. Every spring table now includes data on the ratio of the spring diameter to the compressed height, and the ratio of the horizontal to the vertical spring constants. Our specifications suggest a minimum ratio of 0.75 between the spring diameter and the compressed height as a good working rule, although some of our designs exceed this number.



**SINGLE SPRING
1" (25mm) Deflection
SLFH MOUNT**

All of these springs are designed so as not to exceed the elastic limit when the coils are closed up and the springs are compressed solid. This prevents damage when the springs are overloaded and assures a return to the spring's free height. The rated loads and deflections allow for 50% additional travel to solid to accommodate weight distribution errors and to keep the springs operating in a low stress range. In our Nominal 1" (25mm) Deflection A, B, and C Spring series the smallest rated deflection is 1" (25mm) although some of the lighter springs can deflect as much as 2" (51mm). The springs are used individually or in clusters to develop greater capacity. Some of our B2 and C2 springs only meet competitive criteria and do not have 50% additional travel. This is clearly noted in our catalog Data Sheet DS-208.



**MULTIPLE SPRING
1" (25mm) Deflection
SLF MOUNT**

In an effort to develop a foolproof simple isolator using these sophisticated springs, we have merely added a neoprene friction pad on the bottom to help prevent the passage of noise and a spring loading and adjustment bolt at the top with a locking cap screw. You will find that these adjustment bolts are very substantial because they must be made rigid enough to maintain the alignment of the top of the spring with the base plate, and the head of the bolt is actually the equipment supporting surface. The bolts are tapped to receive the locking cap screw as this methods makes it easy to remove the isolator for servicing. The 5" (127mm) deflection springs are sometimes furnished with three adjustment bolts in a tripod arrangement to maintain the top plate stability. Other stabilizing methods use single oversized bolts or pull-down brackets. In some cases **SLF** mountings with smaller deflections are similarly designed when there are large horizontal forces such as in the isolation of a horizontal compressor. There is no need to bolt this mounting down in most cases because of the friction pad and the spring's reduction of the horizontal forces before they get down to the base plate.

SLF mountings of the proper deflection are recommended for all vibration control applications where it is not necessary to cope with weight removal or seismic and wind load problems. Excessive discharge pressures can be dealt with by adding mass through the use of floating inertia bases or where mass is not a practical solution, by the addition of horizontal thrust restraints.

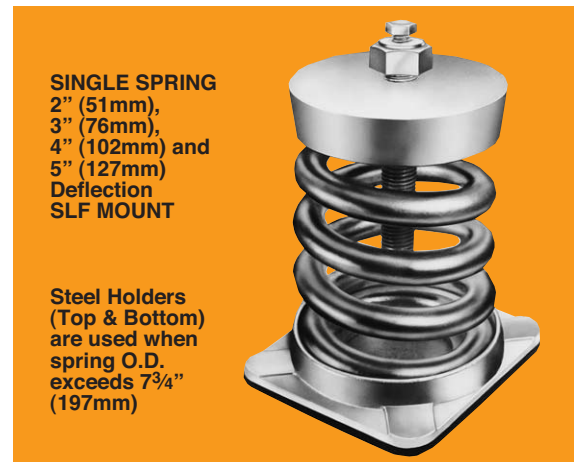

The **SLFH** series of mounts are identical to the style **SLF** except for having two or four holes in the base to allow for bolting to the structure. Since it is expensive to bolt mountings down, and any bolting procedure tends to bypass the acoustical action of the neoprene pad on the bottom of the mounting, it is strongly recommended that you use the Type **SLF** unless the **SLFH** must be used because of elevated installations on steel beams, etc.

BELT DRIVEN CENTRIFUGAL FAN and MOTOR

SLF springs are used to isolate all kinds of fan equipment. Deflections are determined by fan speed, size, motor horsepower and equipment location as discussed in the VCS-100 Engineering Specification and Selection Guide. Bases may be made of structural steel or concrete. The sketch shows a centrifugal fan on a type WFSL base with 3" (76mm) deflection springs.

UTILITY SET

Utility sets are normally direct mounted on 1" (25mm) deflection SLF springs as illustrated. ICS rails are used in conjunction with the springs when higher deflections are required or there is an unsupported fan scroll that causes over balancing. KSL concrete filled bases are recommended for outdoor locations because of the need for wind resistance.

FACTORY ASSEMBLED AIR HANDLING EQUIPMENT

Factory assembled air handling equipment may be direct mounted as shown or placed on ICS rails when higher deflections are called for. It is important to study the equipment base or legs to determine whether rails are needed for structural reinforcement.

FAN HEAD

A fan head develops high horizontal thrust because of the negative pressure on the very large inlet area. The SLF springs cannot handle this thrust without Horizontal Thrust Restraints as sketched or massive concrete filled bases to increase the resistive weight and spring constants.

END SUCTION PUMP or DOUBLE SUCTION PUMP

SLF spring mountings of the proper deflection are recommended for all pump isolation problems. While steel bases may be used, concrete is preferred for greater rigidity and the possibility of grouting in the pump base. Bases should be made large enough to support the suction and discharge elbows whenever possible. Thus, Double Suction bases become wide and End Suction bases long.

SLF applications are by no means limited to these sketches. We have merely tried to illustrate the many modes of application and some of the design considerations.

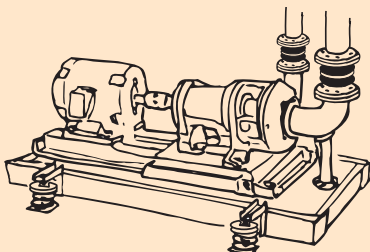
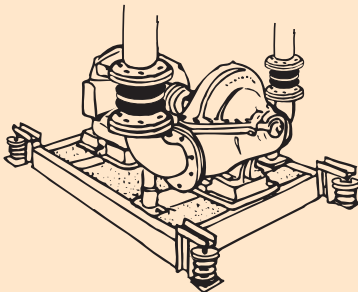
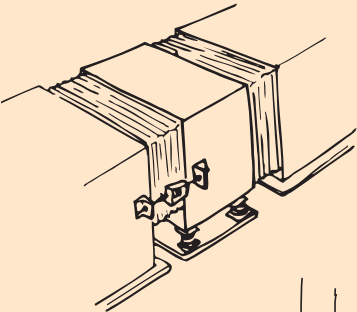
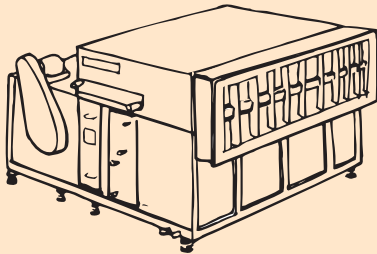
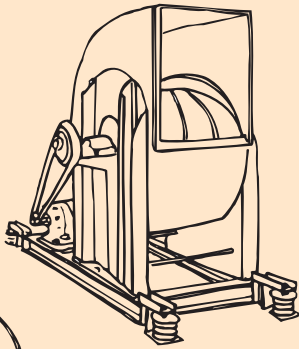
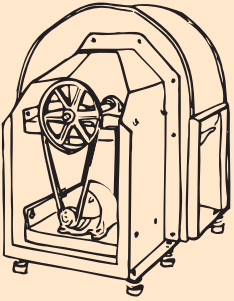

VERTICAL PUMPS

Vertical pump bases using SLF mountings should be made large enough for stability and extended as required to support the piping before attachment to the pump flanges. This piping support reduces the strain on the pump casing.

CLOSE COUPLED PUMP

Close coupled pumps are generally unstable when mounted directly on SLF mountings because they are small in configuration and have a severe overhang on the pump end. A concrete base makes them less sensitive to external forces so the installation becomes much more workmanlike and practical. SLF deflections depend on location and pump size.

DIRECTLY DRIVEN REFRIGERATION COMPRESSOR UNIT

1" (25mm) deflection SLF mountings can be directly attached to the isolated equipment. Mountings of different capacities would be used at the two ends to compensate for the uneven weight distribution and provide reasonably uniform deflection. This use of springs of different capacity but the same potential deflection applies to all isolator selections.

BELT DRIVEN AIR COMPRESSOR

When 2" (51mm) or higher deflection SLF mountings are used we normally recommend ICS rails to minimize elevations. In this particular case the rails project beyond the flywheel to compensate for the overhang. The higher deflections are used to increase efficiency at the low operating speed.

VERTICAL TANK TYPE AIR COMPRESSOR

It is important to exercise caution when applying spring mountings to tall machines with small base dimensions. The use of a concrete filled type K base with SLF mountings lowers the center of gravity in addition to enlarging the base dimensions. Thus, the installation becomes much more stable.

SLOW SPEED VERTICAL or HORIZONTAL COMPRESSOR or VACUUM PUMP

Slow speed, large bore and stroke reciprocating compressors or vacuum pumps have large residual unbalanced forces that make direct mounting impossible because of excessive motion. The concrete inertia block mass is calculated from unbalanced force data supplied by the manufacturer. It is often as much as seven times the equipment weight. Vertical compressors are located over the combined vertical center of gravity. The springs under horizontal compressors are elevated to the horizontal CG. Three adjustment bolts are most important to maintain horizontal SLF stiffness.

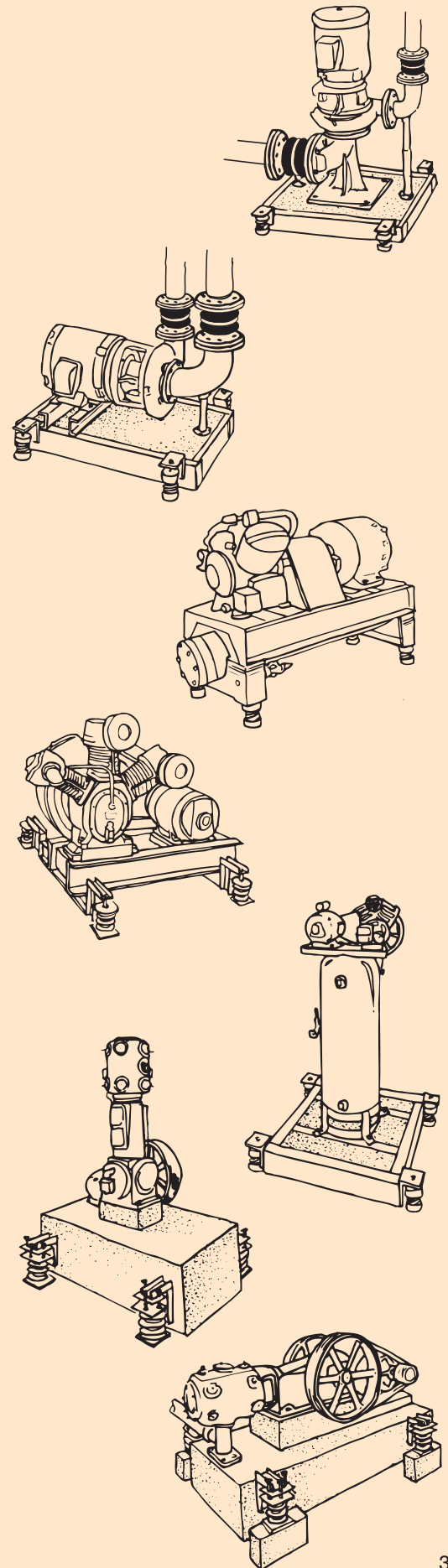

**1" (25mm) Deflection
SLF SINGLE SPRING MOUNTS**

*Change designation to SLFH when
base plate with bolt holes is required.*

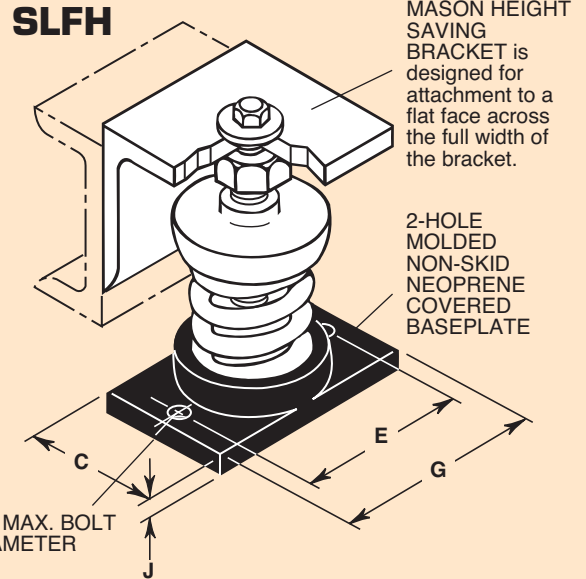
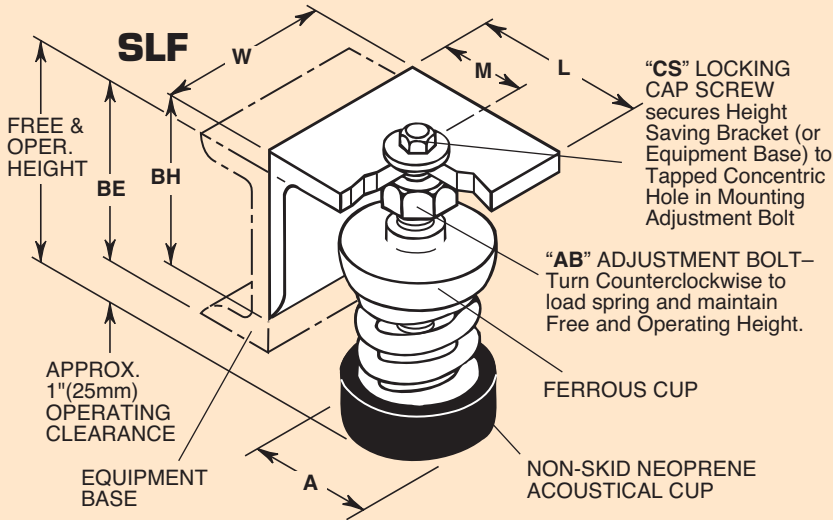

Matching Height Saving Bracket BH- Bracket Height BE- Bracket Elevation

Type	Size	L (in) (mm)	M (in) (mm)	W (in) (mm)	BE (in) (mm)	BH (in) (mm)
SLF-	X	21/2 64	2 51	3 76	23/4 70	2 1/2 64
	A-45 – A-400	21/2 64	2 51	3 76	31/4 83	2 1/2 64
SLFH-	A-510 – A-625	21/2 64	2 51	3 76	35/8 92	2 1/2 64
	B & C	4 102	23/4 70	3 76	5 127	4 102

All springs have additional travel to solid equal to 50% of the rated deflection.
Solid Spring Height = Free Height minus 1.5 times Rated Deflection.

Ratings & Dimensions for 1" (25mm) Deflection Single Spring Mounts (inches millimeters)

Type	Size	Rated Capacity (lbs) (kg)	Rated Defl. (in) (mm)	Spring Constant (lbs/in)(kg/mm)	Spring Color	Spring Only Spring Free OD Height	Free & Oper Ht A	C	E	G	Max. Bolt Dia. H	J	Adjust- ment Bolt AB	Locking Cap Screw CS								
SLF-	X-23†	23 10	1.50 38	18 0.26	Brown	11/2 21/2 38 64	33/4 2	-	-	-	-	-	1/2 x 21/2 x 64	1/4 x 1 x 25								
	X-33†	33 15	1.30 33	30 0.45	Red																	
	X-54†	54 24	1.40 36	45 0.67	White																	
	X-76†	76 34	1.22 31	73 1.10	Black																	
	X-113†	113 51	1.20 30	113 1.70	Yellow																	
	X-130†	130 59	1.20 30	130 1.97	Purple																	
	X-175†	175 79	1.20 30	175 2.63	Silver																	
	X-210†	210 95	1.20 30	210 3.17	Blue																	
	A-45	45 20	1.60 41	28 0.49	Blue										13/4 3 44 76	41/4 21/8	21/4 3	33/4 95	1/4 6	3/8 10	5/8 x 21/2 x 64	3/8 x 1 x 25
	A-75	75 34	1.50 38	50 0.89	Orange																	
A-125	125 57	1.33 34	94 1.68	Brown																		
A-200	200 91	1.15 29	174 3.14	Black																		
A-310	310 141	1.00 25	310 5.64	Yellow																		
A-400	400 181	1.00 25	400 7.24	Green																		
SLFH-	A-510	510 231	1.00 25	510 9.24	Red	13/4 31/8 44 79	45/8 21/8	21/4 3	33/4 95	1/4 6	3/8 10	5/8 x 21/2 x 64	3/8 x 1 x 25									
	A-625	625 283	1.00 25	625 11.32	White																	
SLFH-	B-65	65 29	2.10 53	31 0.55	Brown	23/8 4 60 102	6 23/4	27/8 41/8	53/8 137	1/2 13	3/8 10	7/8 x 41/4 x 108	1/2 x 11/4 x 32									
	B-85	85 39	2.10 53	40 0.74	White††																	
	B-115	115 52	2.00 51	57 1.02	Silver																	
	B-150	150 68	2.00 51	75 1.33	Orange																	
	B-280	280 127	1.60 41	174 3.10	Green																	
	B-450	450 204	1.31 33	344 6.18	Red																	
	B-750	750 340	1.12 28	670 12.14	White																	
	B-1000	1000 454	1.00 25	1000 18.16	Blue																	
SLFH-	C-1000	1000 454	1.00 25	1000 18.16	Black	27/8 41/8 73 105	6 31/4	33/8 43/4	61/8 156	1/2 13	3/8 10	7/8 x 41/4 x 108	1/2 x 11/4 x 32									
	C-1350	1350 612	1.00 25	1350 24.48	Yellow																	
	C-1750	1750 794	1.00 25	1750 31.76	Black*																	
	C-2100	2100 953	1.00 25	2100 38.12	Yellow*																	
	C-2385	2385 1082	1.00 25	2385 43.28	Yellow**																	
	C-2650	2650 1202	1.00 25	2650 48.08	Red*																	
C-2935	2935 1331	1.00 25	2935 53.24	Red**																		

4 †SLFH not available ††with BLACK stripe *with RED inner spring **with GREEN inner spring

**1"(25mm) Deflection
SLF MULTIPLE SPRING MOUNTS**

*Change designation to SLFH when
base plate with bolt holes is required.*

All springs have additional travel to solid equal to 50% of the rated deflection.

Solid Spring Height = Free Height minus 1.5 times Rated Deflection.

Multiple spring mounts have C size springs. SLF-2, SLF-3, SLF-4, SLF-6, SLF-9, SLF-12 & SLF-16 have 2, 3, 4, 6, 9, 12 & 16 springs respectively.

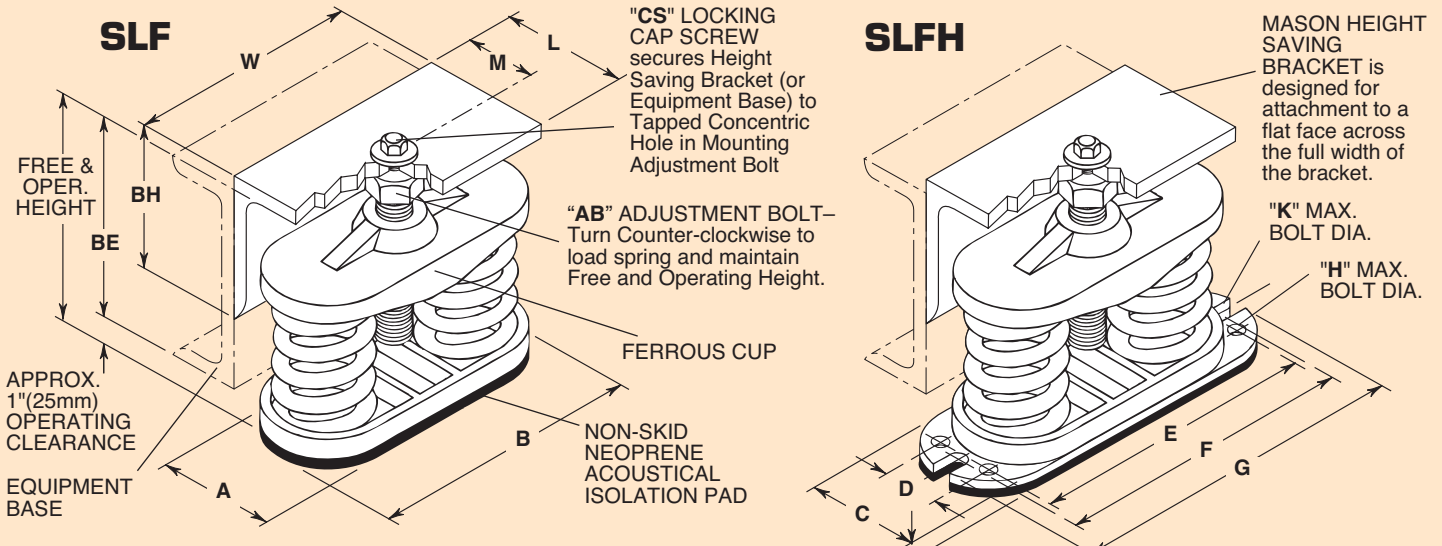

Matching Height Saving Bracket

BH- Bracket Height
BE- Bracket Elevation

Type	Size	L (in) (mm)	M (in) (mm)	W (in) (mm)	BE (in) (mm)	BH (in) (mm)
SLF- SLFH-	2	4 102	2 1/2 64	6 152	5 127	4 102
	3	4 102	2 1/2 64	7 178	5 127	4 102
	4	6 152	4 102	8 1/2 216	5 127	6 152
	6	7 178	5 127	11 3/4 298	5 127	7 178
	9	8 203	5 1/2 140	11 3/4 298	5 1/4 133	7 178
	12 16		Mounts have 2 adjustment bolts and special brackets are required.			

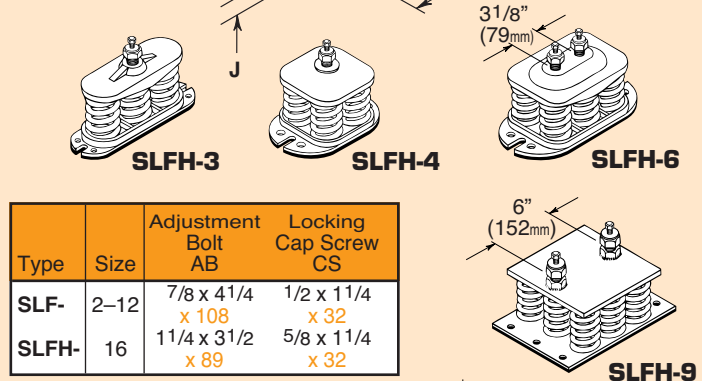

Type	Size	Adjustment Bolt AB	Locking Cap Screw CS
SLF-	2-12	7/8 x 4 1/4 x 108	1/2 x 1 1/4 x 32
SLFH-	16	1 1/4 x 3 1/2 x 89	5/8 x 1 1/4 x 32

Ratings & Dimensions for 1"(25mm) Deflection Single Spring Mounts (inches millimeters)

Type	Size	Rated Capacity (lbs) (kg)		Rated Defl. (in) (mm)	Spring Constant (lbs/in)(kg/mm)		Spring Color/Stripe	Spring Only		Dimensions (inches)										Hole Max. Bolt Dia. H	Slot Max. Bolt Dia. K		
		Free	Spring		Free	Spring		Spring	Free	Spring	Free	Spring	Free	Spring	Free	Spring	Free	Spring	Free			Spring	
SLF-	2-2700	2700	1225	1.00	25	2700	49.00	Yellow	27/8	41/8	6	3 1/4	7 3/4	3 1/4	13/4	8 1/4	8 1/2	10	5/16	1/2	3/8		
	2-3500	3500	1588	1.00	25	3500	63.52	Black*			73	105	152	83	197	83	44	210	216	254	8	13	10
	2-4200	4200	1905	1.00	25	4200	76.20	Yellow*															
	3-5250	5250	2381	1.00	25	5250	95.24	Black*	27/8	41/8	6	3 3/8	9 1/2	3 3/8	13/4	10	10 1/4	11 3/4	5/16	1/2	3/8		
	3-6300	6300	2858	1.00	25	6300	114.32	Yellow*			73	105	152	86	241	86	44	254	260	298	8	13	10
	3-7155	7155	3245	1.00	25	7155	129.80	Yellow**															
3-7950	7950	3606	1.00	25	7950	144.24	Red*																
4-5400	5400	2449	1.00	25	5400	97.96	Yellow	27/8	41/8	6	6 1/4	6 1/4	6 1/4	2 1/4	7 1/2	7 1/2	9 3/8	1/2	1/2	1/2			
4-7000	7000	3175	1.00	25	7000	127.00	Black*			73	105	152	159	159	57	191	191	238	13	13	13		
4-8400	8400	3810	1.00	25	8400	152.40	Yellow*																
SLFH-	6-12600	12600	5715	1.00	25	12600	228.60	Yellow*	27/8	41/8	6	6 3/8	9 1/2	6 3/8	2 1/4	10 3/4	10 3/4	12 5/8	1/2	1/2	1/2		
	6-14310	14310	6491	1.00	25	14310	259.64	Yellow**			73	105	152	161	241	161	57	273	273	321	13	13	13
	6-15900	15900	7212	1.00	25	15900	288.48	Red*															
	6-17610	17610	7988	1.00	25	17610	319.52	Red**															
	9-18900	18900	8573	1.00	25	18900	342.92	Yellow*	27/8	41/8	7	9	9	9	6	11	—	12 1/2	1/2	1/2	—		
	9-21465	21465	9736	1.00	25	21465	389.44	Yellow**			73	105	178	229	229	229	152	279	—	318	13	13	—
	9-23850	23850	10818	1.00	25	23850	432.72	Red*															
	12-25200	25200	11431	1.00	25	25200	457.24	Yellow*	27/8	41/8	7	9	12	9	6	14	—	15 1/2	1/2	1/2	—		
	12-28620	28620	12982	1.00	25	28620	519.28	Yellow**			73	105	178	229	305	229	152	356	—	394	13	13	—
	12-31800	31800	14424	1.00	25	31800	576.96	Red*															
16-33600	33600	15241	1.00	25	33600	609.64	Yellow*	27/8	41/8	8	12	13	12	6	15	—	16 1/2	1/2	1/2	—			
16-38160	38160	17309	1.00	25	38160	692.36	Yellow**			73	105	203	305	330	305	152	381	—	419	13	13	—	

*with RED inner spring **with GREEN inner spring

Mounts in gray area have steel holders top and bottom.

2"(51mm), 3"(78mm), 4"(102mm) & 5"(127mm) Deflection 100 Series SLF SPRING MOUNTS

Change designation to SLFH when base plate with bolt holes is required.

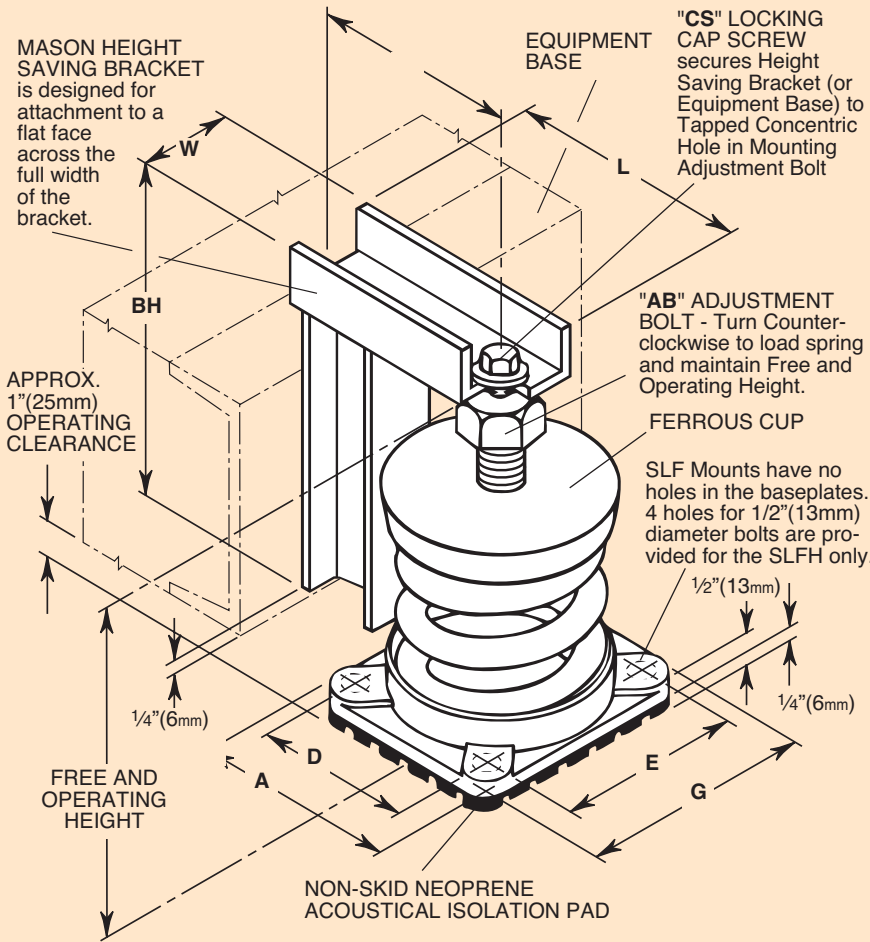

All springs have additional travel to solid equal to 50% of the rated deflection.
Solid Spring Height = Free Height minus 1.5 times Rated Deflection.

Matching Height Saving Bracket

BE - Bracket Elevation

Type	Size	L (in) (mm)	M (in) (mm)	W (in) (mm)	BH (in) (mm)		
2" 51mm Defl.	101-107	6 152	5 127	3 76	9 229		
	108	7 1/2 191	6 1/2 165	3 76	10 1/4 260		
	109	7 1/2 191	6 1/2 165	3 76	10 3/4 273		
	110	8 1/4 210	7 1/4 184	4 102	11 3/4 298		
	111	8 1/4 210	7 1/4 184	4 102	11 3/4 298		
	112	8 1/4 210	7 1/4 184	4 102	12 1/4 311		
	113	12 305	10 1/2 267	6 152	14 3/4 375		
	114	12 305	10 1/2 267	6 152	16 3/8 416		
	115	12 305	10 1/2 267	6 152	16 3/8 416		
	116	12 1/2 318	11 279	6 152	17 1/2 445		
117	Mounts have special adjustment bolts and brackets as required.						
118	Mounts have special adjustment bolts and brackets as required.						
3" 76mm Defl.	126-130	7 1/2 191	6 1/2 165	3 76	10 1/4 260		
	131	7 1/2 191	6 1/2 165	3 76	10 3/4 273		
	132	8 1/4 210	7 1/4 184	4 102	11 3/4 298		
	133-137	8 3/4 222	7 3/4 197	4 102	14 356		
	138-139	12 1/2 318	11 279	6 152	17 1/2 445		
	140	13 330	11 1/2 292	6 1/2 152	21 1/2 546		
	141-143	Mounts have special adjustment bolts and brackets as required.					
4" 102mm Defl.	150-153	7 178	6 152	4 102	11 3/8 289		
	154-155	8 1/4 210	7 1/4 184	3 76	12 1/2 318		
	156-158	8 1/4 210	7 1/4 184	3 76	13 1/8 333		
	159	8 1/4 210	7 1/4 184	3 76	14 1/8 359		
	160-162	11 279	9 1/2 241	4 102	17 3/8 441		
	163-165	14 356	12 1/2 318	6 152	21 3/8 543		
	166-167	14 1/2 368	13 330	6 1/2 165	24 1/4 616		
	168-169	Alternate brackets as required. (See page 8)					
	5" 127mm Defl.	174-198	Matching Height Saving Bracket as shown in illustration on page 6. Pulldown Brackets or three Adjustment Bolts are designed for each special application as required. (See page 8)				
		SLF-SLFH-					

Ratings & Dimensions for 2"(51mm) Deflection 100 Series Spring Mounts (inches mm)

Type	Size	Rated Capacity (lbs) (kg)	Rated Defl. (in) (mm)	Mount Constant (lbs/in) (kg/mm)	Spring Color/Stripe	Spring Only				Free & Oper Ht	A	D	E	G	Adjustment Bolt AB	Locking Cap Screw CS
						Spring OD	Free Height									
2" 51mm Defl.	101	125 57	2.50 64	50 0.89	Purple	33/4 95	53/4 146									
	102	200 91	2.50 64	80 1.42	Brown	33/4 95	53/4 146									
	103	310 141	2.50 64	125 2.20	Pink	33/4 95	53/4 146									
	104	500 227	2.50 64	200 3.55	Green	33/4 95	53/4 146	7 1/4 184	4 1/4 108	3 1/4 83	4 102	4 3/4 120		7/8 x 5 3/4	1/2 x 1 1/4	
	105	740 336	2.40 61	310 5.51	Red	33/4 95	53/4 146									
	106	1050 476	2.10 53	500 8.98	White	33/4 95	57/8 149									
	107	1400 635	2.00 51	700 12.45	Blue	33/4 95	57/8 149									
SLF-	108	1660 753	2.05 52	810 14.48	Silver	4 1/2 114	6 3/4 171	8 203	5 127	4 102	4 1/4 108	5 1/4 133		7/8 x 5 3/4	1/2 x 1 1/4	
	109	2250 1021	2.00 51	1125 20.02	Orange	4 1/2 114	7 1/2 191	9 229	5 127	4 102	4 1/4 108	5 1/4 133		7/8 x 5 3/4	1/2 x 1 1/4	
	110	3000 1361	2.00 51	1500 26.69	Gray	5 127	7 1/2 191	9 229	5 1/2 140	4 1/4 108	5 1/4 133	6 1/2 165		x 146	x 34	
	111	4000 1814	2.00 51	2000 35.57	Tan	5 127	7 1/2 191	9 229	5 1/2 140	4 1/4 108	5 1/4 133	6 1/2 165				
SLFH-	112	5300 2404	2.00 51	2665 47.14	Black	5 1/2 140	8 1/2 216	10 254	6 152	4 3/4 121	5 3/4 146	7 178				
	113	7100 3221	2.00 51	3550 63.16	Yellow	6 152	8 3/4 222	10 1/2 267	6 5/8 168	5 1/4 133	6 152	7 1/2 191		1 x 6	1/2 x 1 1/4	
	114	9300 4218	2.00 51	4650 82.71	Blue/Orng	6 3/4 171	10 254	12 305	7 1/2 191	6 1/4 159	6 1/4 159	7 1/2 191		x 152	x 34	
	115	12600 5715	2.00 51	6300 112.06	Blue/Red	6 3/4 171	10 254	12 305	7 1/2 191	6 1/4 159	6 1/4 159	7 1/2 191				
	116	16800 7620	2.00 51	8400 149.41	Blue/White	7 3/4 197	10 1/8 257	13 330	8 1/2 216	7 1/4 184	7 1/4 184	8 1/2 216		11/4 x 8	5/8 x 1 1/2	
	117	28500 12927	2.55 65	11175 198.88	Blue/Silver	8 3/4 222	13 1/8 333	16 406	9 1/2 241	8 1/2 216	8 1/2 216	9 1/2 241		1 1/2 x 8	x 38	
	118	40000 18144	2.10 53	19000 342.34	Blue/Gray	9 3/8 238	13 1/8 333	16 406	10 1/2 267	9 1/2 241	9 1/2 241	10 1/2 267		1 3/4 x 8	x 203	

Ratings & Dimensions for 3”(76mm), 4”(102mm) & 5”(127mm) Deflection 100 Series Spring Mounts (inches mm)

Type	Size	Rated Capacity		Rated Defl.		Mount Constant		Spring Color/Stripe	Spring Only		Free & Oper Ht	A	D	E	G	Adjustment Bolt AB	Locking Cap Screw CS					
		(lbs)	(kg)	(in)	(mm)	(lbs/in)	(kg/mm)		Spring OD	Free Height												
3” 76mm Defl.	126	195	88	3.25	83	60	1.06	Purple	33/4 95	63/8 162	8	203	41/4 108	31/4 83	4	102	43/4 121	7/8x53/4 x 146	1/2x11/4 x 32			
	127	280	127	3.25	83	85	1.53	Brown	33/4 95	61/2 165	8	203	41/4 108	31/4 83	4	102	43/4 121					
	128	390	177	3.25	83	120	2.13	Orange	4	102	61/2 165	8	203	41/2 114	35/8 92	41/4 108	5			127		
	129	520	236	3.25	83	160	2.84	Green	4	102	7 178	8 1/2	216	41/2 114	35/8 92	41/4 108	5			127		
	130	710	322	3.25	83	220	3.88	Red	41/2 114	71/4 184	8 1/2	216	5	127	4	102	41/4 108			5 1/4	133	
	131	940	426	3.25	83	290	5.13	White	41/2 114	71/2 191	9	229	5	127	4	102	41/4 108			5 1/4	133	
132	1280	581	3.25	83	395	7.00	Blue	5	127	77/8 200	9 1/2	241	5 1/2	140	41/4 108	5 1/4 133	6 1/2	165				
SLF-	133	1770	803	3.25	83	545	9.67	Black	5 1/2 140	91/4 235	11	279	6	152	43/4 121	53/4 146	7	178	1 x 6 x 152	1/2x11/4 x 32		
	134	2490	1129	3.25	83	765	13.60	Yellow	5 1/2 140	91/4 235	11	279	6	152	43/4 121	53/4 146	7	178				
SLFH-	135	3300	1497	3.25	83	1000	18.04	Gray	6	152	91/2 241	11	279	65/8 168	51/4 133	6	152	71/2 191	11/4x8 x 203	5/8x11/2 x 38		
	136	4500	2041	3.25	83	1370	24.59	Blue/Brown	63/4 171	93/4 235	11 3/4	298	7 1/2	191	61/4 159	61/4 159	7 1/2	191				
4” 102mm Defl.	137	6200	2818	3.25	83	1900	33.88	Blue/Orng	73/4 197	107/8 276	13 1/4	337	8 1/2	216	71/4 184	71/4 184	8 1/2	216	11/4x8 x 203	5/8x11/2 x 38		
	138	8300	3765	3.25	83	2560	45.36	Blue/Red	73/4 197	11 279	13 1/4	337	8 1/2	216	71/4 184	71/4 184	8 1/2	216				
	139	11400	5171	3.25	83	3500	62.30	Blue/White	73/4 197	12 1/4 311	13 1/4	337	8 1/2	216	71/4 184	71/4 184	8 1/2	216				
	140	15200	6895	3.25	83	4685	83.07	Blue/Silver	83/4 222	123/4 324	16 1/2	419	9 1/2	241	8 1/2	216	8 1/2	216			9 1/2	241
	141	20300	9208	3.25	83	6245	110.94	Blue/Gray	9 1/2 241	13 1/2 343	16 1/2	419	10 1/2	267	9 1/2	241	9 1/2	241			10 1/2	267
	142	28400	12882	3.25	83	8750	155.20	Blue/Green	10 1/4 260	15 381	18	457	11	279	10	254	10	254			11	279
	143	39000	17690	3.25	83	12000	213.13	Blue/Yellow	11 279	16 1/8 410	19	483	12	305	11	279	11	279			12	305
	150	240	109	4.38	121	55	0.98	Purple	5	127	83/8 213	10	254	5 1/2 140	4 1/4 108	5 1/4 133	6 1/2 165	7/8 x 8 x 203			1/2x11/4 x 32	
	151	330	150	4.38	121	75	1.35	Brown	5	127	81/2 213											
	152	420	191	4.38	121	95	1.72	Orange	5	127	83/8 213											
153	530	240	4.38	121	120	2.16	Green	5	127	83/8 213												
154	680	308	4.38	121	155	2.77	Red	6	152	87/8 225												
SLF-	155	880	399	4.38	121	200	3.59	White	6	152	91/8 232	10 3/4	273	65/8 168	5 1/4 133	6	152	71/2 191	1 x 8 x 203	1/2x11/4 x 32		
	156	1120	508	4.38	121	255	4.58	Blue	6	152	97/8 251	12	305	65/8 168	5 1/4 133	6	152	71/2 191				
157	1420	644	4.38	121	325	5.80	Black	6	152	10 212	12	305	65/8 168	5 1/4 133	6	152	71/2 191					
SLFH-	158	1840	835	4.38	121	420	7.52	Yellow	63/4 171	103/8 264	12	305	7 1/2 191	6 1/4 159	6 1/4 159	7 1/2 191	1 x 8 x 203	5/8x11/2 x 38				
	159	2370	1075	4.38	121	540	9.68	Gray	63/4 171	11 1/8 283	13	330	7 1/2 191	6 1/4 159	6 1/4 159	7 1/2 191						
SLFH-	160	3000	1361	4.38	121	695	12.26	Blue/Brwn	73/4 197	107/8 276	14	356	8 1/2 216	7 1/4 184	7 1/4 184	8 1/2 216	11/4 x 8 x 203	5/8x11/2 x 38				
	161	3900	1769	4.38	121	895	15.94	Blue/Red	73/4 197	113/8 289	14	356	8 1/2 216	7 1/4 184	7 1/4 184	8 1/2 216						
	162	5100	2313	4.38	121	1155	20.84	Blue/Orng	83/4 222	11 1/2 292	14	356	9 1/2 241	8 1/2 216	8 1/2 216	9 1/2 241	11/2 x 8 x 203	3/4 x 2 x 51				
	163	6500	2948	4.38	121	1485	26.56	Blue/White	83/4 222	13 1/4 337	17	432	9 1/2 241	8 1/2 216	8 1/2 216	9 1/2 241						
	164	8400	3810	4.38	121	1910	34.32	Blue/Silver	83/4 222	133/8 340	17	432	9 1/2 241	8 1/2 216	8 1/2 216	9 1/2 241						
	165	10800	4899	4.38	121	2455	44.14	Blue/Gray	93/8 238	14 1/8 359	17	432	10 1/2 267	9 1/2 241	9 1/2 241	10 1/2 267	13/4 x 8 x 203	3/4 x 2 x 51				
	166	13800	6260	4.38	121	3160	56.40	Blue/Green	10	254	153/8 391	19	483	11	279	10	254	10	254	11	279	
	167	17800	8074	4.38	121	4065	72.74	Blue/Yellow	11	279	157/8 403	19	483	12	305	11	279	11	279	12	305	
	168	22900	10387	4.38	121	5235	93.58	Blue/Pink	11	279	17 432	20	508	12	305	11	279	11	279	12	305	
	169	30000	13608	4.38	121	6730	122.59	Blue/Tan	11 5/8 295	18 457	21	533	13	330	12	305	12	305	13	330		
5” 127mm Defl.	174	70	122	5.31	135	50	0.90	Purple	6	152	97/8 251	12	305	65/8 168	6 1/4 159	6 1/4 159	7 1/2 191	1 x 9 x 229	1/2x11/4 x 32			
	175	320	145	5.31	135	60	1.07	Brown	6	152	10 1/16 256											
	176	370	168	5.31	135	70	1.24	Orange	6	152	10 254											
	177	460	209	5.38	137	85	1.53	Green	6	152	10 1/2 267											
	178	560	254	5.38	137	105	1.85	Red	6	152	103/4 273	13 1/2	343	65/8 168	6 1/4 159	6 1/4 159	7 1/2 191					
	179	670	304	5.38	137	125	2.22	White	63/4 171	11 1/16 281	13 1/2	343	7 1/2 191	7 1/4 184	7 1/4 184	7 1/2 191	1 x 10 x 254	1/2x11/4 x 32				
	180	830	376	5.38	137	155	2.74	Blue	63/4 171	11 3/8 289												
	181	1000	454	5.38	137	185	3.31	Black	63/4 171	11 1/8 283												
	182	1240	562	5.37	136	230	4.13	Yellow	63/4 171	11 3/8 289												
	SLF-	183	1500	680	5.37	136	280	5.00	Gray	73/4 197	127/16 316	15	381	8 1/2 216	7 1/4 184	7 1/4 184	8 1/2 216	11/4 x 10 x 254	5/8x11/2 x 38			
184		1830	830	5.37	136	340	6.10	Pink	73/4 197	117/8 302												
SLFH-	185	2230	1012	5.37	136	415	7.44	Silver	73/4 197	12 305	73/4 197	12 305	73/4 197	12 305	73/4 197	12 305	73/4 197	12 305				
	186	2710	1229	5.37	136	505	9.04	Tan	73/4 197	123/4 324	73/4 197	123/4 324	73/4 197	123/4 324	73/4 197	123/4 324	73/4 197	123/4 324				
	187	3300	1497	5.37	136	615	11.01	Blue/Orng	83/4 222	123/4 324	15	381	9 1/2 241	8 1/2 216	8 1/2 216	9 1/2 241	11/2 x 10 x 254	3/4 x 2 x 51				
	188	4100	1860	5.37	136	755	13.68	Blue/Red	83/4 222	133/8 340	16	406	9 1/2 241	8 1/2 216	8 1/2 216	9 1/2 241						
	189	4900	2223	5.37	136	915	16.35	Blue/White	91/16 230	137/16 341	16	406	9 1/2 241	8 1/2 216	8 1/2 216	9 1/2 241						
	190	6000	1852	5.37	136	1120	20.01	Blue/Yelw	9 1/2 241	145/8 371	17	432	10 1/2 267	9 1/2 241	9 1/2 241	10 1/2 267						
	191	7300	2252	5.37	136	1365	24.35	Blue/Silvr	9 1/2 241	153/16 386	17 1/2	445	10 1/2 267	9 1/2 241	9 1/2 241	10 1/2 267						
	192	9000	2777	5.37	136	1670	30.01	Blue/Gray	10 1/4 260	155/8 397	18	457	11	279	10	254	10	254	11	279		
	193	11000	3395	5.37	136	2040	36.69	Blue/Tan	10 1/4 260	16 406												
	194	13300	6033	5.37	136	2482	44.36	Blue/Brown	11 279	16 1/4 413	19	483	12	305	11	279	11	279	12	305		
195	16300	7394	5.37	136	3028	54.37	Blue/Pink	11 3/8 289	17 1/8 435	20	508	12	305	11	279	11	279	12	305			
196	19800	8981	5.37	136	3694	66.04	Blue/Black	11 5/8 295	18 457	21	533	13	330	12	305	12	305	13	330			
197	24200	10977	5.37	136	4506	80.71	Blue/Green	13 330	19 1/2 495	23	584	14	356	13	330	13	330	14	356			
198	29000	13154	5.27																			

Alternate bracket and spring adjustment methods to improve stability and appearance when using 4" (102mm), 5" (127mm) and greater deflection springs.

PULL-DOWN BRACKET

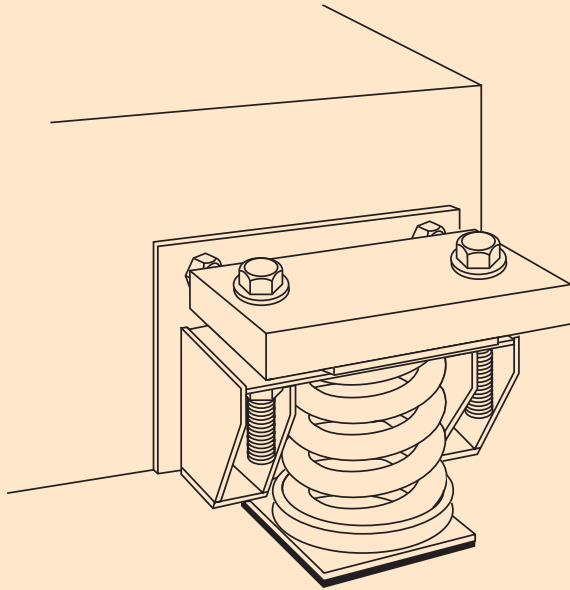

3 ADJUSTMENT BOLTS

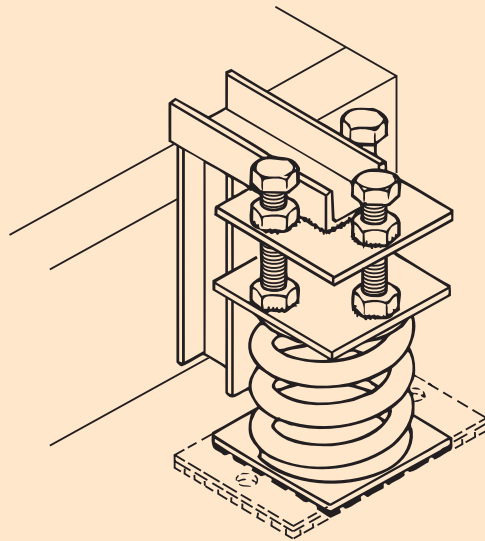

SPRING CHARACTERISTICS

Spring Size	Rated Deflection	Ratio Kx/Ky	Ratio OD/OH	Spring Size	Rated Deflection	Ratio Kx/Ky	Ratio OD/OH
X	1.00-1.30	0.75-1.00	0.92-1.40	101-118	2.00-2.55	0.71-1.10	0.82-1.15
A	1.00-1.60	0.50-0.90	0.74-1.25	126-143	3.25	0.72-1.00	0.85-1.36
B	1.00-2.10	0.70-0.90	0.80-1.25	150-169	4.38	0.80-1.10	0.85-1.33
C & Multiples	1.00	0.90-1.10	0.92	174-198	5.27-5.38	0.70-1.00	0.92-1.31

PRODUCT FINISHES

All standard products have a painted finish unless otherwise indicated.

Special finishes include:

- Zinc Chromate
- Neoprene Dipping
- Cold Galvanized Paint
- Epoxy Finish
- Hot Dipped Galvanized Holders with Electro-Galvanized or Cadmium Plated Hardware, depending on size and method of attachment. Springs in these holders will be made rust resistant.



MASON INDUSTRIES, INC.

350 Rabro Drive, Hauppauge, NY 11788 • 631/348-0282 • FAX 631/348-0279
 2101 W. Crescent Ave., Suite D • Anaheim, CA 92801 • 714/535-2727 • FAX 714/535-5738
 Email info@Mason-Ind.com • info@MasonAnaheim.com • Website www.Mason-Ind.com